

No. 8500

Double Flanged Pipe FF

EN 545 (DIN 28614)

working pressure max. PN 16

of ductile iron EN-GJS-400-18
according to EN 1563 (GGG 400 - DIN
1693) epoxy powder coated

flanges according to EN 1092-2 (DIN
28605)

standard drilling to DIN 2501 - PN 10

* also available drilled to DIN 2501 -
PN 16 (please specify on order)

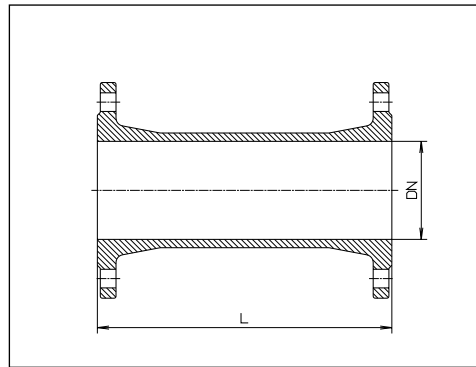

DN	L	Weight kg	
50	200	7,50	●
50	400	10,00	●
65	200	9,50	●
65	400	13,00	●
80	200	9,20	●
80	400	12,50	●
80	600	15,70	●
80	800	18,90	●
80	1000	22,00	●
100	200	10,70	●
100	400	15,00	●
100	600	19,00	●
100	800	23,00	●
100	1000	27,00	●
125	200	13,30	●
125	400	18,50	●
125	600	24,00	●
125	800	29,00	●
125	1000	34,50	●
150	200	16,50	●
150	400	23,00	●
150	600	29,50	●
150	800	36,00	●
150	1000	42,50	●
*200	200	23,00	●
*200	400	32,50	●
*200	600	41,50	●
*200	800	51,00	●
*200	1000	60,00	●

No. 8550

Double Flanged Taper FFR

EN 545 (DIN 28645)

working pressure max. PN 16

of ductile iron EN-GJS-400-18
according to EN 1563 (GGG 400 - DIN 1693)
epoxy powder coated

flanges according to EN 1092-2
(DIN 28605)

standard drilling to DIN 2501 - PN 10

* also available drilled to DIN 2501 -
PN 16 (please specify on order)

+ of grey iron

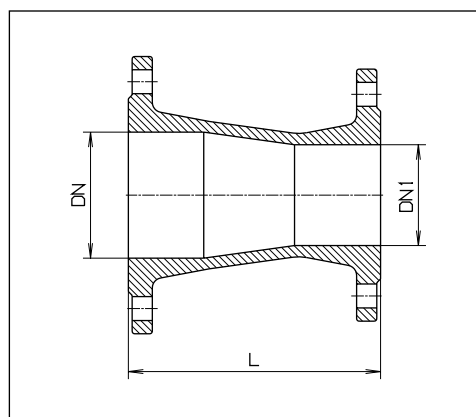

DN	DN 1	L	Weight kg	
65	50	200	9,00	●
80	50	200	7,40	●
80	65	200	8,20	●
100	50	200	8,10	●
100	65	200	8,80	●
100	80	200	9,50	●
+125	65	400	19,00	●
125	80	200	10,70	●
125	100	200	11,40	●
150	80	200	12,20	●
150	100	200	12,80	●
150	125	200	14,10	●
*200	100	300	18,60	●
*200	125	300	20,00	●
*200	150	300	22,00	●

Flanged Fittings

No. 8540

Double Flanged Bend 45° FFK 45°

EN 545 (DIN 28639)

working pressure max. PN 16
of ductile iron EN-GJS-400-18
according to EN 1563 (GGG 400 -
DIN 1693) epoxy powder coated
flanges according to EN 1092-2
(DIN 28605)

standard drilling to DIN 2501 - PN 10

* also available drilled to DIN 2501 -
PN 16 (please specify on order)

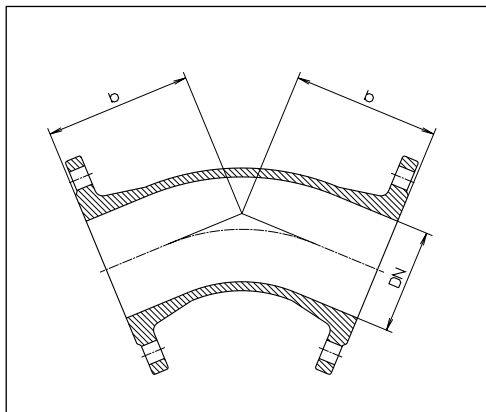

DN	b	Weight kg	
50	150	9,00	●
65	165	12,00	●
80	130	9,50	●
100	140	11,50	●
125	150	14,60	●
150	160	18,70	●
*200	180	27,50	●

No. 8530

Double Flanged Bend 90° Q 90°

EN 545 (DIN 28637)

working pressure max. PN 16
of ductile iron EN-GJS-400-18
according to EN 1563 (GGG 400 -
DIN 1693) epoxy powder coated
flanges according to EN 1092-2
(DIN 28605)

standard drilling to DIN 2501 - PN 10

* also available drilled to DIN 2501 -
PN 16 (please specify on order)

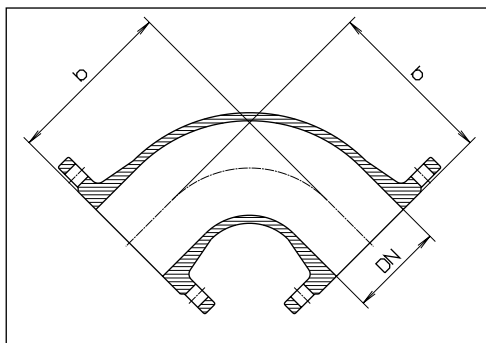

DN	b	Weight kg	
50	150	9,30	●
65	165	9,70	●
80	165	9,90	●
100	180	11,90	●
125	200	15,60	●
150	220	20,50	●
*200	260	31,00	●

No. 8510

All Flanged Tee

T

EN 545 (DIN 28643)

working pressure max. PN 16
of ductile iron EN-GJS-400-18
according to EN 1563 (GGG 400 -
DIN 1693) epoxy powder coated
flanges according to EN 1092-2
(DIN 28605)

standard drilling to DIN 2501 - PN 10

* also available drilled to DIN 2501 -
PN 16 (please specify on order)

+ of grey iron

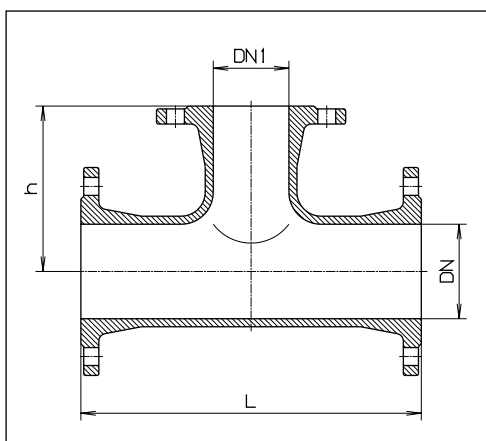

DN	DN 1	L	h	Weight	
50	50	300	150	12,50	●
65	50	330	157	15,50	●
65	65	330	165	16,50	●
80	50	330	160	14,00	●
80	65	330	165	14,70	●
80	80	330	165	16,00	●
100	50	360	170	16,60	●
100	65	360	170	17,40	●
100	80	360	175	18,60	●
100	100	360	180	19,40	●
125	50	400	185	21,50	●
+125	65	450	195	31,00	●
125	80	400	190	23,00	●
125	100	400	195	24,00	●
125	125	400	200	25,50	●
+150	50	500	200	27,50	●
+150	65	500	207	39,00	●
150	80	440	205	29,00	●
150	100	440	210	29,50	●
150	125	440	215	31,00	●
150	150	440	220	32,00	●
*200	80	520	235	42,50	●
*200	100	520	240	43,00	●
*200	125	520	245	44,00	●
*200	150	520	250	46,50	●
*200	200	520	260	50,00	●